

1500LB BW

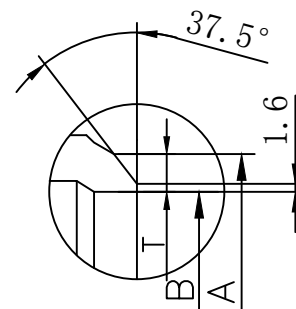
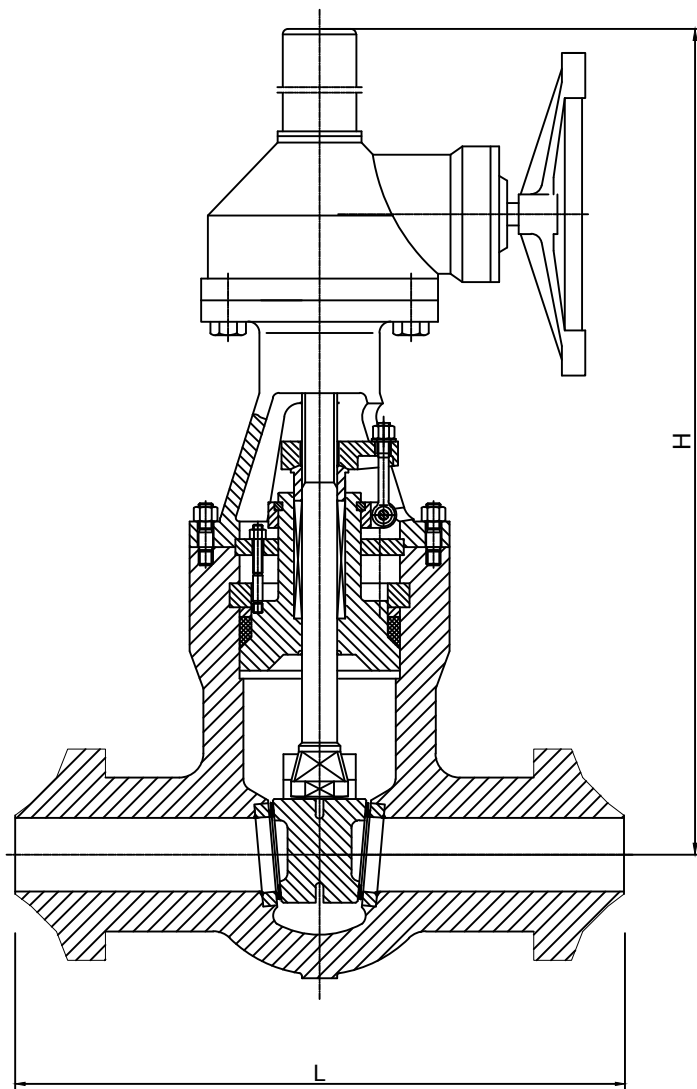

NPS	L	A	B	T	H
2"	368	60.3	52.5	3.9	582
2-1/2"	419	75	62.7	5.2	635
3"	470	91	74	7.6	781
4"	546	117	97	8.55	876
6"	705	172	146	10.95	1104
8"	832	223	194	12.7	1142
10"	991	278	243	15.1	1786
12"	1130	329	289	17.5	1955
14"	1257	362	318	19.05	2057
16"	1384	406	364	24.45	2311
18"	1537	457	398	29.35	2438
20"	1664	516	456	26.2	2590
24"	1943	619	548	30.95	2946

Performance	
Nominal pressure	1500LB
Strength test pressure	39.0
Seal test pressure	28.6
Air seal pressure	0.6
Max. temperature	≤ 425°C
Water.oil.gas etc.	Medium

Technical Specifaion

- 1、 Design & manufacture according to API 600;
- 2、 Butt weld size dimension according to ASME B16.25;
- 3、 Structure length size dimension according to ASME B16.10;
- 4、 Inspection & test according to API 598;

GATE VALVE		Construction
Page 1		
		1500LB BW